

RULES

2026

Stillaguamish Valley Horsemen (SVH) was established in 1977 by a group of families to promote the sport of Pattern Horse Racing, also known as Western Games. SVH strives to promote a family oriented atmosphere where all ages and levels of riders and horses can come together to enjoy sportsmanship, friendly competition and family values.

Established in 2013 and referencing the rule books of Snohomish County Western Games Association (SCWGA) and the National Saddle Clubs Association (NSCA), this rule book was formed to provide continuity of events between SVH shows. The primary underlying rule is always that common sense prevails. These specific rules were created to provide a standard of reference for board members and participants.

The O-Mok-See Prayer

Dear Lord,

We pause, mindful of the many blessings you have lain along our path. We don't ask for special favors, nor do we ask that the blessings granted our opponents be diminished. Instead, we thank you for allowing us to experience friendship in one of its truest forms. To be able to gather with friends and loved ones to pay tribute to the great sport of O-Mok-See. We ask that you guide us up the greatest lane of all, and that you, as our final judge will allow us to ride once more, where the sun never sets and where happiness rides beside us and never behind.

For this dear Lord, we thank you.

SVH BASIC RULES

Common sense is the primary rule.

Boots with a heel must be worn while riding anywhere on the grounds.

All riders on a horse in the arena must have signed a release. All minors must have a release signed by a parent or guardian.

1. CONDUCT

- A. Any unsportsmanlike conduct or profanity is grounds for disqualification or dismissal with no entry fee refunded for the event or for the day, at the discretion of the board.
- B. A rider may be disqualified for abuse of arena equipment or abuse of a horse any place on the grounds.
- C. Excessive whipping, excessive spurring, or striking the animal in an abusive manner will immediately disqualify that rider. Cruelty to animals will not be tolerated by anyone at any time on the grounds.

2. ARENA LAYOUT

- A. Lane measurements common to all events are shown in a diagram or description of individual events.
- B. When the course is measured, the measurement shall be taken from the center of the barrels, poles or containers. A course may be moved for safety reasons. If a course is re-set for initial wrong measurement, all riders in that class must re-run.

3. MISCELLANEOUS

- A. Lead line is a non-competitive class.
- B. Age groups may be adjusted at beginning of each season.
- C. The Novice class is for anyone who is truly a novice rider or brand new to gaming. This class is designed to encourage new riders to this sport. This class is for beginner riders, not horses, and if you are an experienced rider we encourage you to ride in your age group. If, after the first show, you are competitive in the majority of the events in your appropriate age group, you may be moved by the board to your age group for all future shows. Riders may only compete in the novice class for one season.
- D. All stallions must be identified by having a yellow ribbon in their tail.
- E. Any horse may be asked to be removed from the grounds at any time at the discretion of the board.

4. CONTESTANT'S EQUIPMENT

- A. Breakage of contestant's equipment shall not entitle any contestant to a re-run in any games event.
- B. Western equipment to be used shall be: a saddle with horn, bridle type optional.
- C. Helmets are not required but recommended.

5. DURING COMPETITION

- A. No horse or rider shall compete against themselves in the same age group.
- B. Riders shall be considered mounted with the knee over the center line of the horse's back.
- C. Breakage of property shall not entitle any competitor to a re-run in any games event.
- D. No property shall be re-set until the rider has finished the course.
- E. Contestants may not ride out of age group.
- F. Rider accepts the course when they cross the start/finish line.

6. RE-RIDES AND TIES

- A. In the event of a missed time or timer malfunction, a contestant with a clean ride will be given two chances to make a qualified run.
- B. Re-rides must be made in the original lane and on the same horse.
- C. In the event of interference, one re-ride shall be offered at the discretion of the judge. The rider must accept the re-ride before leaving the arena. The rider has the option of completing the re-ride before they leave the arena or at the end of their class.
- D. In the event of interference, the rider must have been safe up to the point of such interference in order to receive the option of a re-ride.
- E. In the event of a tie both riders will receive equal points of the highest placing.

7. JUDGING AND INTERPRETATIONS

- A. The decision of the judge, or judges, will be final. (No video camera replay.)
- B. All complaints and protests will go to the board.

8. GENERAL DISQUALIFICATIONS

- A. Failure to complete the course as described.
- B. Crossing the start/finish line before permission is granted to start by the announcer.
- C. Failure to start within 30 seconds of the announcer granting permission, or failure to start the course within 1 minute of first attempt to enter arena.
- D. Knocking down, dropping, or moving stationary properties outside of a two foot radius of its original location.
- E. Stopping the timer before completion of course by any portion of horse, rider or properties.
- F. Whipping or striking the horse with properties of the event, including before or after the start/finish line.
- G. Unsportsmanlike conduct. The judges may disqualify riders for use of profane language, unnecessary roughness, excessive use of bat, quirt, or spurs, and disorderly conduct of any kind.
- H. Having a loose horse during a pattern, defined as separated from, or out of control of, contestant.
- I. Teams will be disqualified if horse waiting his turn crosses the course at the starting line before the horse completing the course crosses the finish line completely.
- J. All four of the horse's feet step out of lane at the same time, once entered the intended lane.
- K. Contestant becomes dismounted on course, unless specified for the pattern.

EVENT EQUIPMENT

1. The following equipment shall be used whenever any of the terms are used in event descriptions.
2. Equipment color and size to match in each lane.

Barrels- 55 gallon standard plastic.

Flags-The flag consists of a staff and attached flag. Staff to be 1-1/16" wood dowel, 5' long. Flag to be sturdy cloth. The flag is wrapped completely around staff leaving 8"x8" portion free. The event shall have light and dark colored flags.

International Flag and Can-The international flag consists of a staff and attached flag. Staff to be wood dowel, 16" long. Flag to be sturdy cloth. The flag will be wrapped completely around staff leaving 3-1/2" high x 5-1/2" long portion free. Can to be standard 3lb coffee can to be filled with arena soil.

Quarter Barrels-15 gallon standard metal barrel. Barrel to be filled with 8-10 inches of arena soil.

Ribbon-5' long x 2" wide sturdy material.

Pole-Combination of pole base and pole. Pole base of standard commercial solid rubber base or commercial sand filled plastic base. Pole to be 1 1/2" PVC pipe, 80" long.

Scurry Jump Support-Commercial standard Plastic jump can be used to support Jump Pole.

Scurry Pole-Jump pole to be 14' in length and 3" PVC.

Stake-1" wood dowel, 5' long.

Timers- Electronic timers to be Farmtek brand or equivalent. All lanes to have same type of timers.

Tomahawk-Made from 1/2" standard stall mat cut in the shape of a tomahawk. Handle is 12"L x 2" W, overall length is 15" L. Mark handle 6" from bottom.

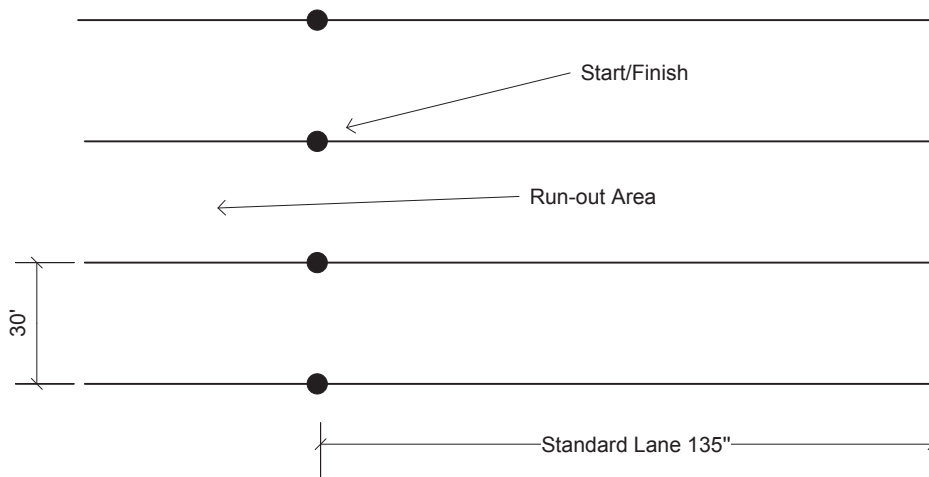

Lane Dimensions

All events to be centered in lane.
Number of lanes to be determined by Arena.
Timers to be set on lane edge at starting point.
End line at 135' from starting line unless otherwise noted in event description.
Minimum run-out distance is 60'.

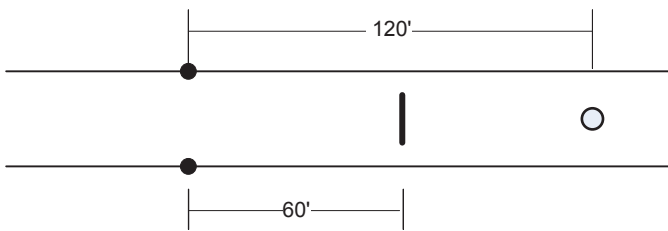

1 JUMP SCURRY

Jump pole and jump base to be set at 60' from start line. Barrel to be set at 120' from start line.

Jump heights:

On ground for Lead line

9" for Youth and Junior

17" for Intermediates and up

Contestant to jump over scurry pole, make a right or a left turn at barrel, jump over scurry pole and run back to finish line. All 4 feet must pass over jump.

Disqualification on the 4th balk in either direction.

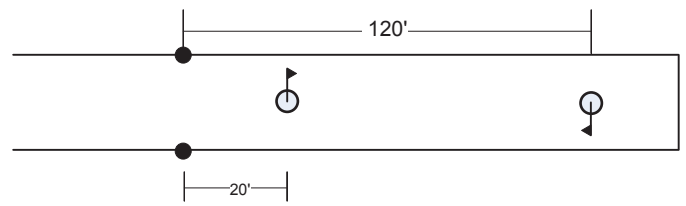

2 BARREL FLAGS

Quarter barrels to be set at 20' and 120' from start line.

1 Flag of different color to be placed in each quarter barrel. Standard setting of Flags is for right hand pick up unless rider otherwise requests.

Contestant to pick up flag at closest quarter barrel, make a right or a left turn at 2nd quarter barrel, placing the first flag in the 2nd quarter barrel, pick up the next flag and place in the 1st quarter barrel on the same side as the turn on the 2nd quarter barrel and run back to finish line. Flags must remain in quarter barrels until the rider crosses the finish line. If flag is broken, the rider is safe if the larger portion of the flag is still in quarter barrel.

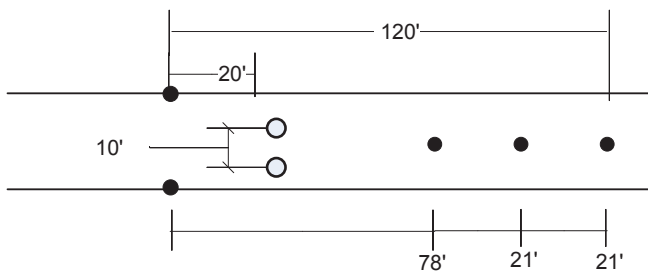

2 BARREL POLES

78' 21' 21'

2 barrels set 21' from starting line and 10' space in between. 3 poles set at 78', 99' and 120' from start line.

Contestant to run to the barrel on the right side first, make a right turn, make a figure 8 pattern with both barrels, go to poles, begin weave at closest pole, weave all poles, at end pole, turn and weave back through all poles, run back straight between both barrels to finish line.

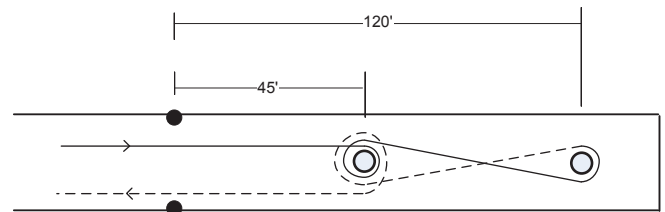

360-8

2 barrels set at 45' and 120' from start line.

Contestant to run down, make a complete left or right circle at closest barrel, go to end barrel make a opposite turn, weave to closest barrel, make a complete opposite circle and run to finish line.

"Polo-Weave-Polo"

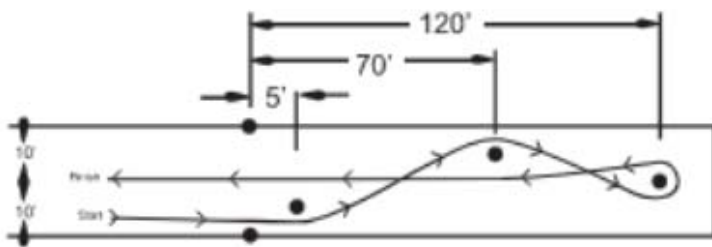

3 POLE WEAWE

Rider runs between pole #1 and the outside lane, then runs between pole #2 and outside lane, then runs to pole #3, make a left hand turn around pole #3, then run back to finish line.

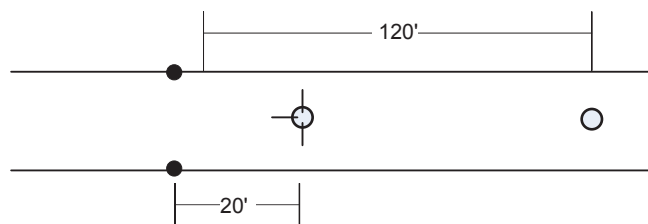

BARREL & STAKE

Quarter barrels to be set at 20' and 120' from start line. 3 Stakes to be placed in barrel set at 20'.

Contestant to pick up one stake at a time, make a right or a left turn at farthest quarter barrel, placing the stake in the farthest quarter barrel. Remainder of stakes to be run the same. When 3rd stake is placed contestant to run back to finish line. Stake must remain in quarter barrels until the rider crosses the finish line. If stake is broken, the rider is safe if the larger portion of the flag is still in quarter barrel.

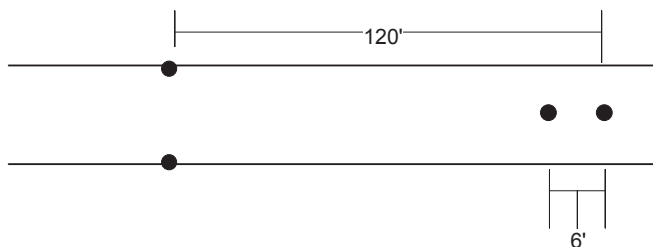

HALF 8

End Pole to be 120' from starting line, second pole to be 6' from end pole towards starting line.

Contestant to run to poles on either side, enter space between poles, turn end pole and run straight back to finish line.

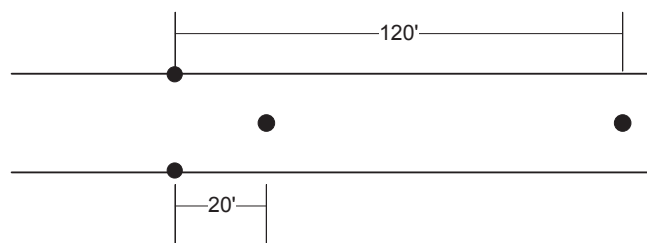

IDAHO FIGURE 8

End Pole to be 120' from starting line, second pole to be 20' from starting line.

Contestant to run to end pole, make a left or right turn, then make an opposite turn at the second pole, then make an opposite turn at the end pole and run back to finish line.

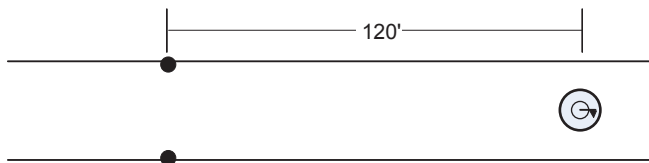

INTERNATIONAL FLAG

Barrel set at and 120' from start line.
Coffee can centered on barrel.
International flag set in center of coffee can.

Contestant to run down, make a left or right turn pick up International flag and run back to finish line with international flag. All equipment to remain in upright position.

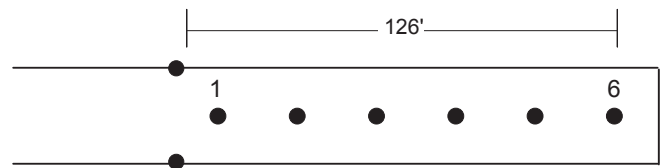

KEG RACE

6 Traffic cones or 5 gallon buckets.
Cone #1 to be 21' from starting line and 21' apart.

Contestant to begin weaving cones at cone #1 on either side, continue weave through all cones. At cone #6 turn and weave back through all cones, and run back to finish line.

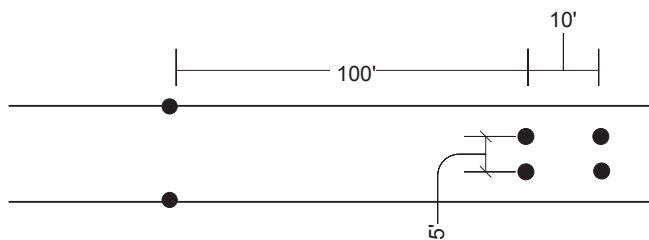

KEY RACE

2 poles 5' apart, centered in lane at 100' from starting line. 2 poles 5' apart, centered in lane at 110' from starting line.

No end line.

Contestant to run through the 5' opening of all 4 poles, make a right or left turn and run back through 5' opening of all poles to finish line.

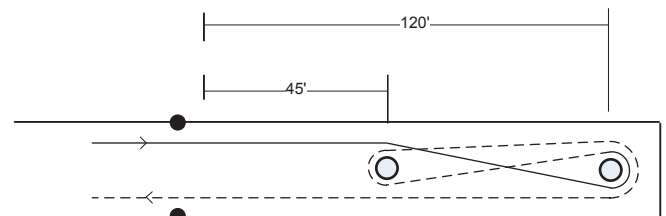

LANE BARRELS

2 barrels set at 45' and 120' from start line.

Contestant runs to closest barrel, make a right or left weave to farthest barrel, make an opposite turn, weave back to closest barrel, make turn in the same direction towards farthest, make a turn in the same direction as closest barrel and run to finish line.

“Weave-Weave-Straight-Straight”

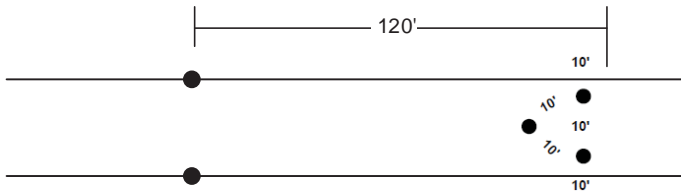

LITTLE FLYING W

Can be run from either side. If starting on the right. Make a left turn on the right pole, make a right turn on center pole, make a left turn on left pole, then run to finish line.

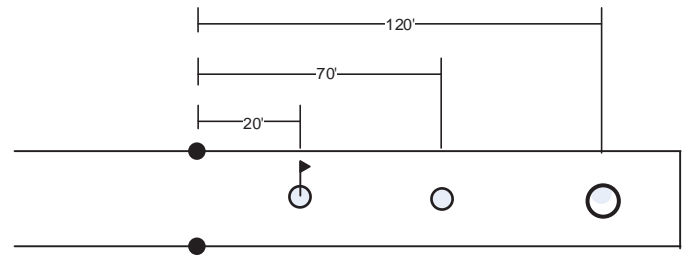

MIGHTY EAGLE

Rider picks up flag from 1st barrel and places in center barrel, then turns the end barrel and picks up the flag from the center barrel and places in the 1st barrel then runs back to finish line.

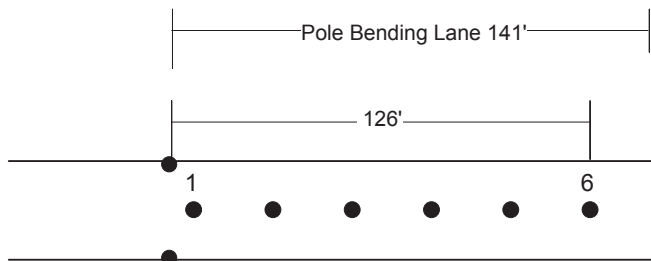

POLES

Pole #1 to be 21' from starting line and 21' apart. End line at 141' from starting line.

Contestant to run to pole #6, make a left or right turn, weave through all poles. At pole #1 turn and weave back through all poles, turn at pole #6 and run back to finish line.

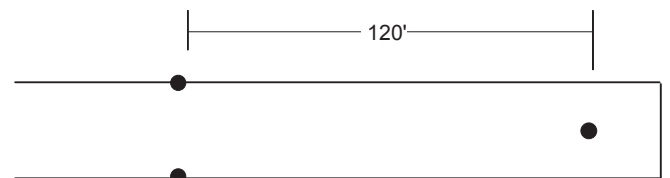

POLO TURN

Pole to be set at 120' from start line. Contestant to make a right or left complete circle around pole and run back to finish line.

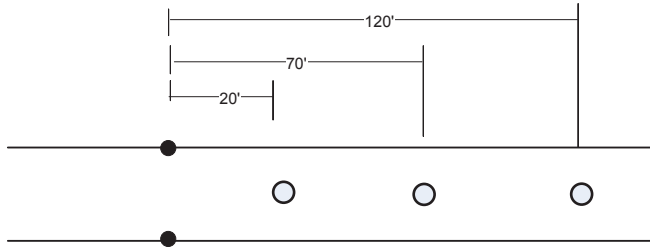

SPEED BARRELS

3 barrels set at 20', 70' and 120' from start line.

Contestant to start weave at first barrel on either side, weave all barrels, make a turn on the same side as the starting barrel, weave back through all barrels and run to finish line.

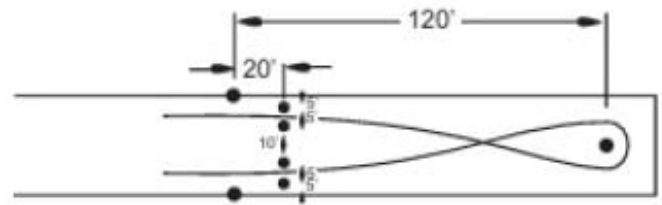

SPUR RACE

Contestant can start on either side of the lane. Contestant rides between on pair of poles, crosses over and turns the end pole and returns on the opposite pair of poles to run to finish line.

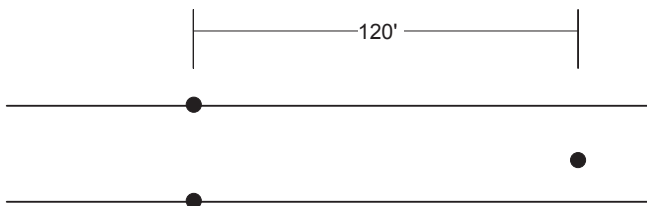

STAKE

Pole to be set at 120' from start line.
Contestant to make a right or left at end pole and run back to finish line.

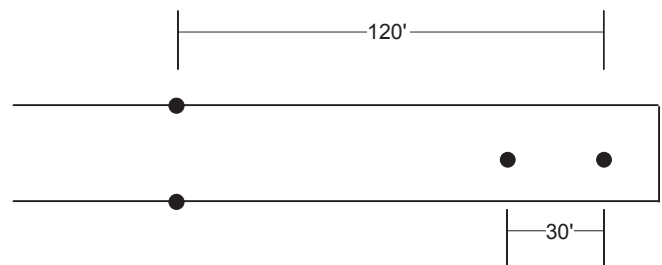

STILLY FIGURE 8

Contestant to run to end pole, make a left or right turn, then make an opposite turn at the second pole, then make an opposite turn at the end pole and run back to finish line.

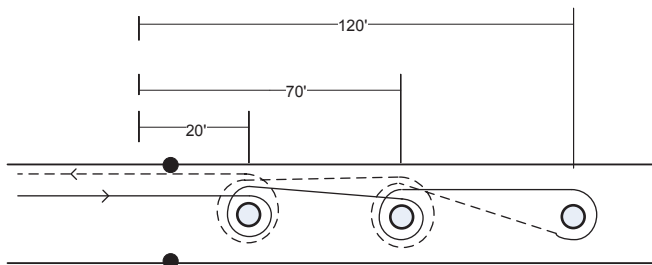

STRAIGHT BARRELS

3 barrels set at 20', 70' and 120' from start line.

Contestant to run down, make a left or right turn at closest barrel, go to middle barrel make a turn on the same side as the starting barrel, go to farthest barrel, make a turn in the same direction as the first two barrels, weave to middle barrel, make an opposite turn at closest barrel, turn closest barrel on the same side as middle barrel and run to finish line.

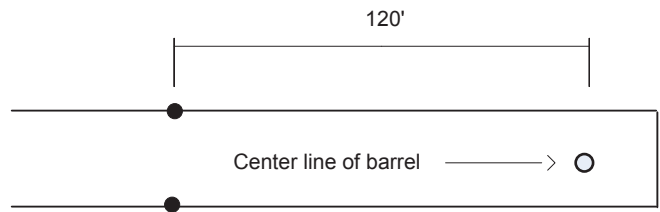

TEXAS ROLLBACK

Barrel set at 120' from start line.

No end line.
Contestant to run on either side of barrel, make an opposite turn behind the center line of the barrel and run back on opposite side of the starting run to finish line.

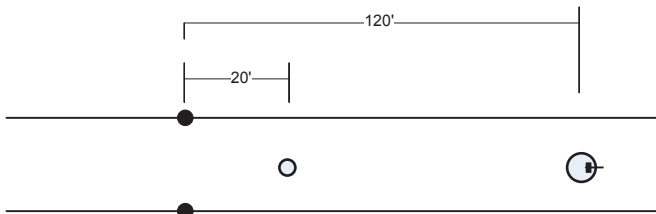

TOMAHAWK

1 barrel set at 120' from start line.
1 quarter barrel set 20' from start line.
1 tomahawk placed on barrel with handle 6" over farthest edge from start line.

Contestant to run down on either side and pick up tomahawk, put tomahawk in quarter barrel and run to finish line.
Disqualification for weaving barrels.

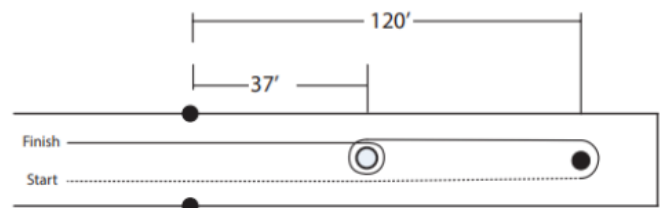

TOP & TURN

Contestant may start on either side and run to the pole making either a right or left turn, and then same turn at the barrel and run to finish line

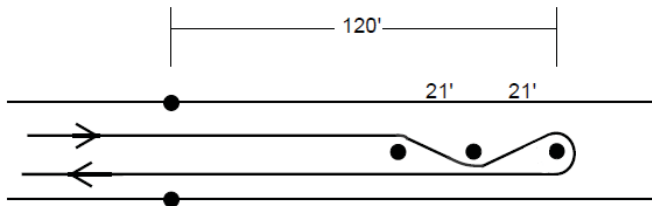

COTTER PIN

Rider runs to 1st pole and weaves 2nd pole, turns end pole, then runs straight back home. Rider can start on right or left hand side.

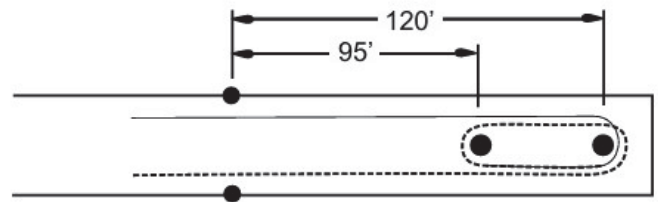

BIG O

Rider runs to end barrel, then to 1st barrel, then back to end barrel, then straight back to home. Rider can start on right or left hand side.

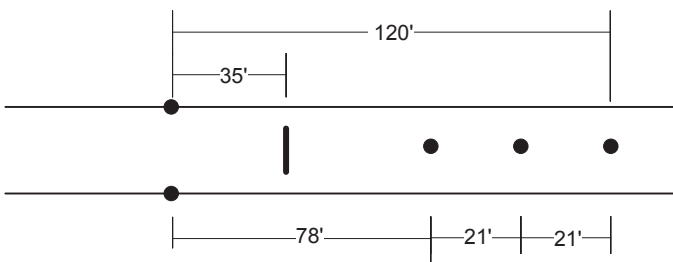

WESTERN JUMPING

Jump pole and jump base to be set at 35' from start line. 3 poles set at 78', 99' and 120' from start line.

Jump heights:

On ground for Lead line 9" for Youth and Junior 17" for Intermediates and up

Contestant to jump over scurry pole, begin weave on either side of closest pole, weave all poles, turn end pole on the same side as first pole, weave back through all poles, jump over scurry pole and run back to finish line. All 4 feet must pass over jump. Disqualification on the 4th balk in either direction.

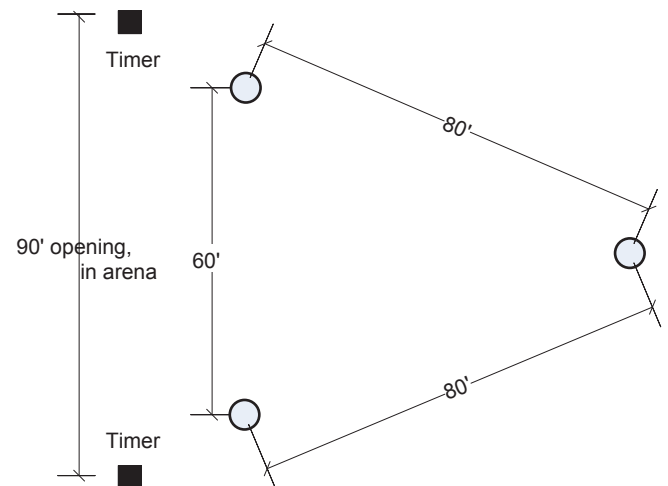

BARRELS

Equipment, 3 barrels.

Contestant to run to right or left closest barrel, make a right or left hand turn, run to next closest barrel, make an opposite turn, run to 3rd barrel, make turn in the same direction and run to finish line through two closest barrels.

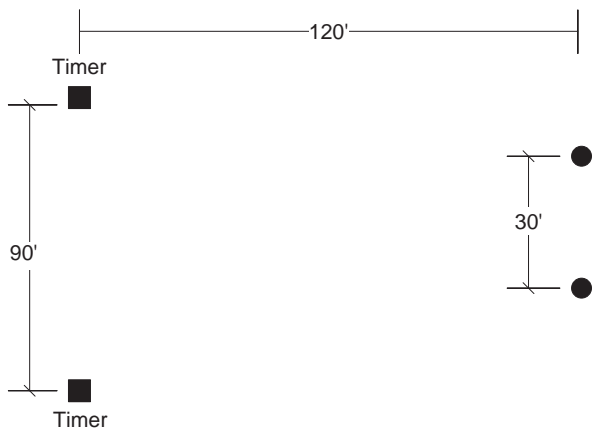

BIWRANGLE

Starting line & timers set at 90' apart, no side lines or end lines. 2 poles 30' apart centered in arena at 120' from starting line.

Can be run from either pole. If starting on right pole, make right turn, run to left pole, make right turn and run to finish line.

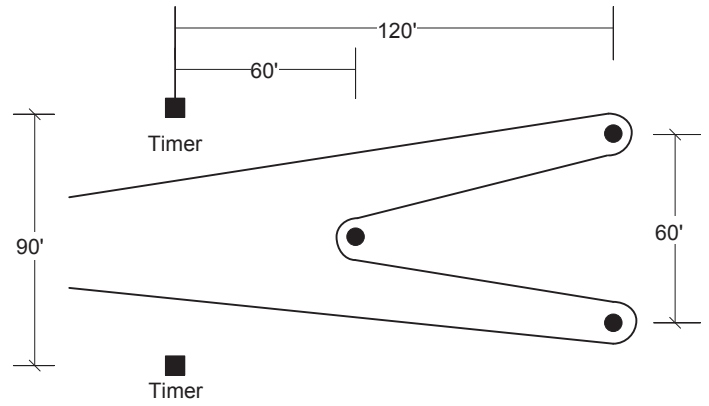

FLYING W

Starting line & timers set at 90' apart, no side lines or end lines.
 2 poles 60' apart centered in arena at 120' from starting line.
 1 pole centered in arena at 60' from starting line.

Can be run from either farthest pole. If starting on right, make a left turn, turn, then run to center pole, make a right turn, run to third pole, make a left turn and run to finish line.

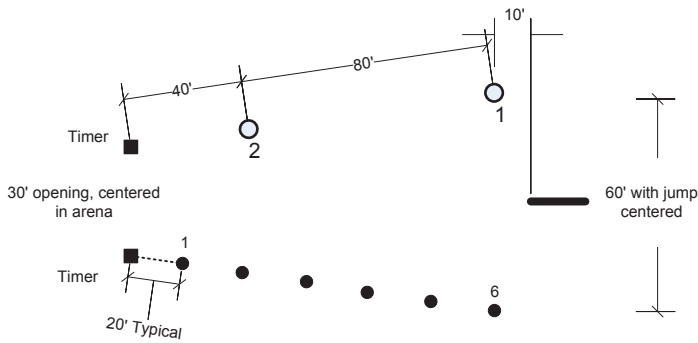

GYMKHANA JIG

Starting line & timers set at 30' apart, no side lines or end lines.

6 poles 20' apart in a line from the right start/timer. Pole #6 set at 30' from center of course.

Place 5 or 6 traffic cones between right timer and pole #1. 1 jump centered on course and 10' from center line of barrel #1

2 barrels 80' apart in a line from left start/timer. Barrel #1 set at 30' from center of course.

Jump heights: On ground for Lead line 9" for Youth and Junior 17" for Intermediates and up.

Contestant to run to pole #1, start weave on right side, weave all poles, then jump over scurry pole, run to barrel #1, make left turn, run to barrel #2, make right turn, run to barrel #1, make left turn, pass between barrels and run to finish line. All 4 feet must pass over jump.

Disqualification on the 4th balk in either direction.

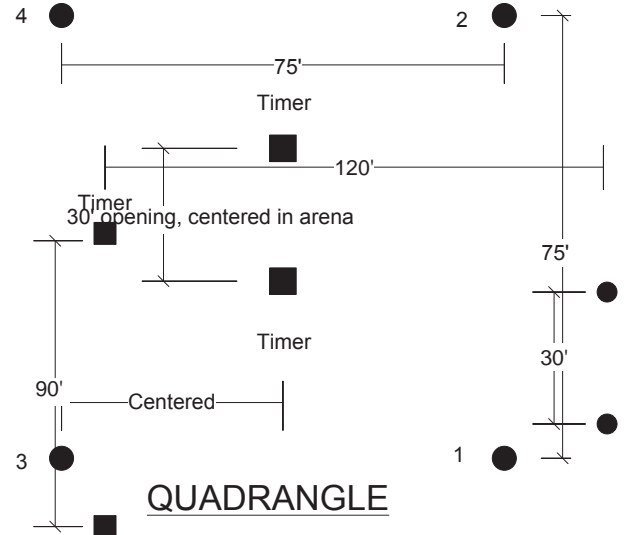

QUADRANGLE

Starting line & timers set at 30' apart centered in arena, no side lines or end lines.

4 poles 75' apart centered in arena.

After timer is started by contestant, timer to be turned off, after contestant runs through start line the 2nd pass, timer to be turned on, contestant will stop timer on 3rd pass. Event Contestant to start by passing through timers, run to pole #1, make right turn, run to pole #2, make right turn, head to pole #3 passing through timers, at pole #3 make left turn, run to pole #4, make left turn, run to finish line passing through timers.

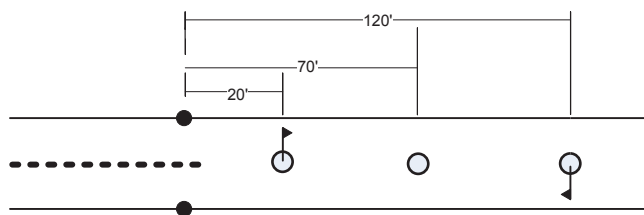

2 MAN-3 BARREL FLAGS

Quarter barrels to be set at 20' & 120' from start line. 1 Flag of different color to be placed in each quarter barrel. Standard setting of Flags is for right hand pick up unless rider otherwise requests.

Cones set at 2' apart in center of lane in run-out area to starting line.

First rider to pick up flag at closest quarter barrel, place flag in middle quarter barrel, make a right or a left turn at farthest quarter barrel, pick up flag and place in middle quarter barrel, and run to finish line. Second rider to follow the same direction of first rider and pick up flags from middle quarter barrel and place flags in original quarter barrels and run to finish line. Flags must remain in quarter barrels until the rider crosses the finish line. If flag is broken, the rider is safe if the larger portion of the flag is still in quarter barrel. The line of cones in the run-out area is to provide a safe separation of riders.

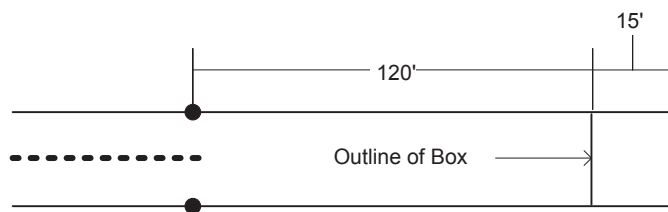

KANSAS LEADBACK

Equipment- Standard lane dimensions with chalked box. Cones set at 2' apart in center of lane in run-out area to starting line.

Team Description-Mounted rider to run to box, dismount and lead horse back and cross finish line in front of the horse. After first rider crosses finish line, second mounted rider to run course as described.

Reins not to exceed 7' in length. The use of a strap, lead rope attached to head of horse is allowed. First rider cannot step outside of box. The line of cones in the run-out area is to provide a safe separation of riders. This pattern can also be run as an individual event.

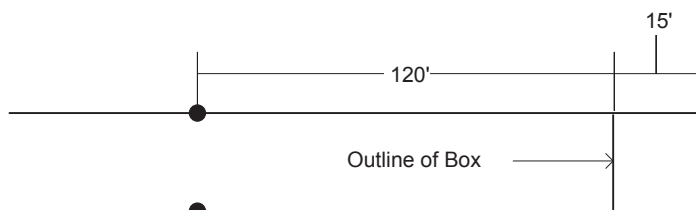

RESCUE RACE

Equipment- Standard lane dimensions with chalked rescue box.

Partner to be rescued stands in box, Rider races to box and picks up partner. Partner must make an attempt to be mounted while in box. Both rider and partner must be mounted when crossing finish line. Contestants cannot step outside of box until mounted.

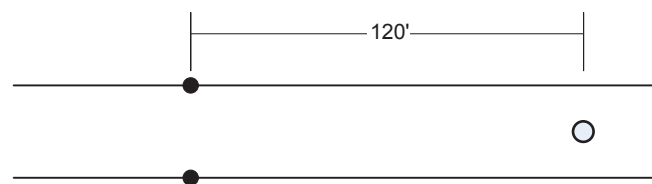

RIBBON RACE

Barrel to be set 120' from starting line. One-5' ribbon per team.

Both riders start race holding the ribbon between them, must make a left turn at barrel and run to finish line with ribbon still in hand of each rider. Letting go of Ribbon before finishing race is a disqualification.

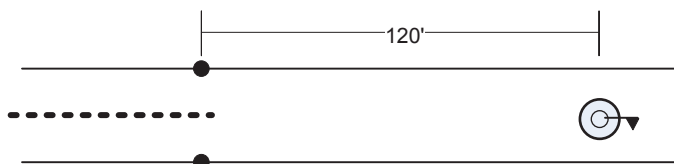

TEAM INTERNATIONAL FLAG

Barrel set at and 120' from start line.
 Coffee can centered on barrel, half full of arena soil. International flag.
 Cones set at 2' apart in center of lane in run-out area to starting line.

First rider with international flag, make a left or right turn set International flag in coffee can and run back to finish line
 second rider to follow the same pattern as 1st rider and pick up international flag and run home with all equipment still in upright position. The line of cones in the run-out area is to provide a safe separation of riders.

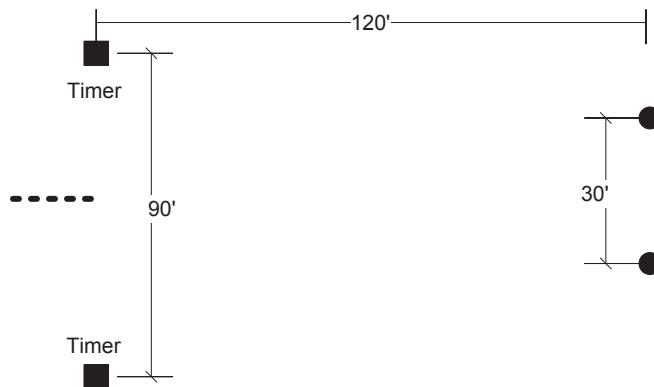

TEAM TWO MAN STAKE

Starting line & timers set at 90' apart, no side lines or end lines. 2 poles 30' apart centered in arena at 120' from starting line.
 Cones set at 2' apart in center of lane.
 Can be run from either pole. If starting on right pole, first rider makes right turn, run to left pole, make right turn and run to finish line. Second rider completes the same pattern as first rider. The line of cones in the run-out area is to provide a safe separation of riders.

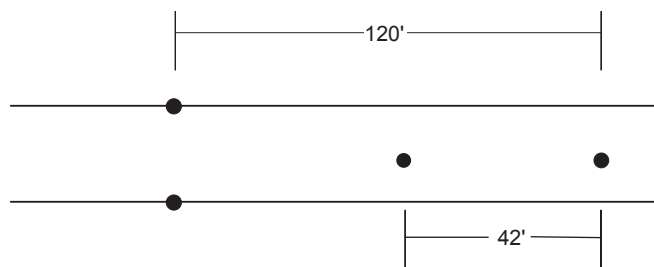

TEAM JUST-N-OTHER PAIR

Both riders start race holding the ribbon between them, weaves right or left between poles, turns end pole, weaves back with ribbon still in hand of each rider.
 Letting go of Ribbon before finishing race is a disqualification.

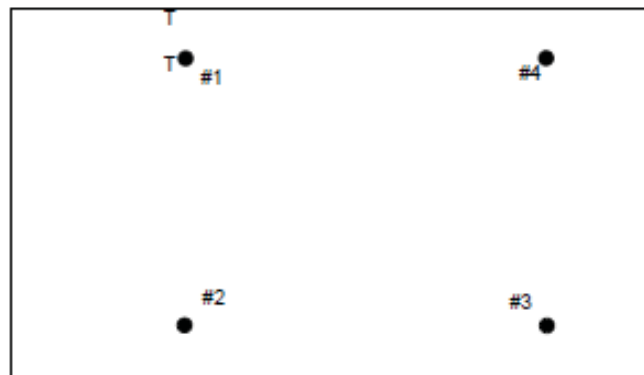

TEAM WESTERN RELAY

Barrels to placed on outside four corners of arena lanes (3 or 4 lanes) or minimum 15' clearance from barrels to arena fence. All riders to enter center of box created by 4 barrels. Start/Finish line to be between barrel #1 & fence.
 1st rider to start between barrel #1 & barrel #4, races around arena in direction of barrel #2 continuing around outside of barrels, passing baton to the 2nd rider between barrel #1 & barrel #4, continuing until all riders have completed the course. Last rider to wear red arm band on right arm. Upon completion of the course all riders must either stay at start/finish area of the arena or return to the center of the arena. Disqualification for dropping the baton, going on the inside of any barrel, failure to pass baton between between barrel #1 & barrel #4.